

Xtreme Products Inc.

Kit No. XTS750 '08 up Suzuki King Quad 750

Read these instructions carefully. Xtreme recommends, a professional mechanic perform the installation. Care should be taken to follow all standard safety procedures.

A thorough inspection of the suspension should be made prior to performing the installation. Any worn, bent or broken parts should be replaced. After installation another inspection should be made, checking for loose components or missing hardware. Inspect, again after eight hours of operation.

To begin, check to make sure all components and necessary tools are on hand.

Components:

The kit consists of four bags containing Hardware and Brackets.

Bag #1 for the Left Front

Bag #3 for the Left Rear

Bag #2 for the Right Front

Bag #4 for the Right Rear

Disassembly / Installation Procedure

1.)Begin by loosening the lug nuts on both front tires. Raise the unit, using a suitable lifting device or procedure, until the front tires are off the ground. If using a floor jack with stands, chock the rear wheels to prevent the unit from rolling. If using jack stands, make sure the stands are placed under the frame and not the body. Make sure the unit is **stable and secure**.

2.)Remove the tires / wheels.

NOTE: Now is a good time to check the threads on the lug studs. Check for rust, pulled threads or other deterioration that could cause a stud/thread failure.

3.)Remove contents from Bag #1. This bag is for the drivers left front wheel. Looking at the assembly sheet for bag #1 follow these instructions. Loosen the lower shock attaching bolt. Remove the top shock bolt and pull the top of the shock out and away from the frame.

NOTE: As you pull the top of the shock out you will notice that it hits the plastic splash shield (inner fender). You will have to trim away some of the splash shield to clear the new brackets as the top of the shock will be moved out from it's stock position. You can cut this with a razor knife or tin snips. Trim out a small amount and you can trim the rest later. You want clearance but you do not want excessive gaps so trim a little at a time.

Take a 10x55 (fine thread) bolt from the bag and using the drawing as an example insert the bolt through the -03 bracket. Going from front of bike to rear insert the bolt into the factory mount, install the 3/4x1 sleeve from the bag and now install the -01 bracket. Be sure the -01 is on the outside of the frame tube as shown in the drawing. Tighten the bolt enough to make sure the threads are engaged at this time.

4.)Insert the 1/4" u-bolt from the bag and attach the -01 bracket to the frame tube. Tighten these bolts finger tight.

5.)Attach the -04 bracket, this is the long bracket with the two notches cut in it, to the -03 using the 5/16 bolt and nut included in the bag. Let the opposite end hang for the time being.

Note: *Be sure the notches in the bar are facing up. There is also a metal brake line coming from the master cylinder, if the -04 bracket makes contact push the line to the rear for clearance.*

- 6.) Insert the shock into the new position and tighten all bolts **except** the 5/16.
- 7.) Proceed the other side and repeat the preceding steps with one change. **The -02 bracket goes behind the frame tube on the right hand side. This will require you to place the tang behind the frame rail prior to inserting it into the factory shock mount.** Be sure you do not pinch any wires between the bracket and frame tube.
- 8.) After tightening all bolts be sure the 5/16 bolts are tight in the -04 cross-member.

Rear Lift

- 9.) First lift and remove the tires then remove the bottom sway-bar attaching nut from the link on both sides. Disengage the link from the control arm and push the sway bar up out of your way. This will allow the rear wheels to drop and be independent from each side.
- 10.) Start with the right side and completely remove the shock for ease of installation. Proceed to the left side, take the top shock bolt out and loosen the bottom shock bolt. Pull the top of the shock out as far as possible. On the left side, going from rear to front, insert a 10x55 bolt through the -09 bracket into the stock shock mount and through the sleeve furnished Continuing through the stock mount and through the -06 bracket. **NOTE: There are clearance notches cut into the bracket to clear the factory belt exhaust.** Place a nut on the bolt, do not tighten at this time. Place the other 10x55 through the brackets and shock installing the 10mm washers as shown in the diagram. Use the supplied u-bolts and nuts to attach the 09 bracket to the frame tube.

NOTE: *There is a storage box on the left rear that will cause some interference. You may try installing the -09 bracket, washer and shock on the bolt before placing the other washer and -06 bracket on the bolts. It is easier for some install it this way.*

- 11.) Repeat the basic steps performed on the left side on the right. It is easier to insert the shock with the top going in under the top mount and the bottom being placed in the factory mount first. Install the top bolt, washers and brackets as shown and then installing the lower shock bolt. Tighten all the hardware for both shocks at this point.
- 13.) Place the -07 sway bar relocation bracket on the link-attaching stud and install the stock nut. Install the 3/8x3/4 from the front through the -07 bracket and into the stock mounting hole. Loosely install the 3/8 nut. Install the 5/16 bolt and nut and tighten both attaching bolts. Tighten the main attaching bolt **ONLY** after you have both sides installed.

Note: *We highly recommend that you apply an "anti-seize" compound such as Never-Seize to the lug studs at this time. This compound will save you time and money in the long run and will not cause the lugs to come loose as some suggest.*

WARRANTY: This kit will be warranted against defects in workmanship and materials **ONLY**. Problems from misuse, improper installation or abuse are not covered in the warranty. This warranty is good for one year (12 months) from date of purchase. All warranty claims **MUST** be accompanied by the original receipt or suitable proof of purchase date.

ASSEMBLY FOR BAG #1

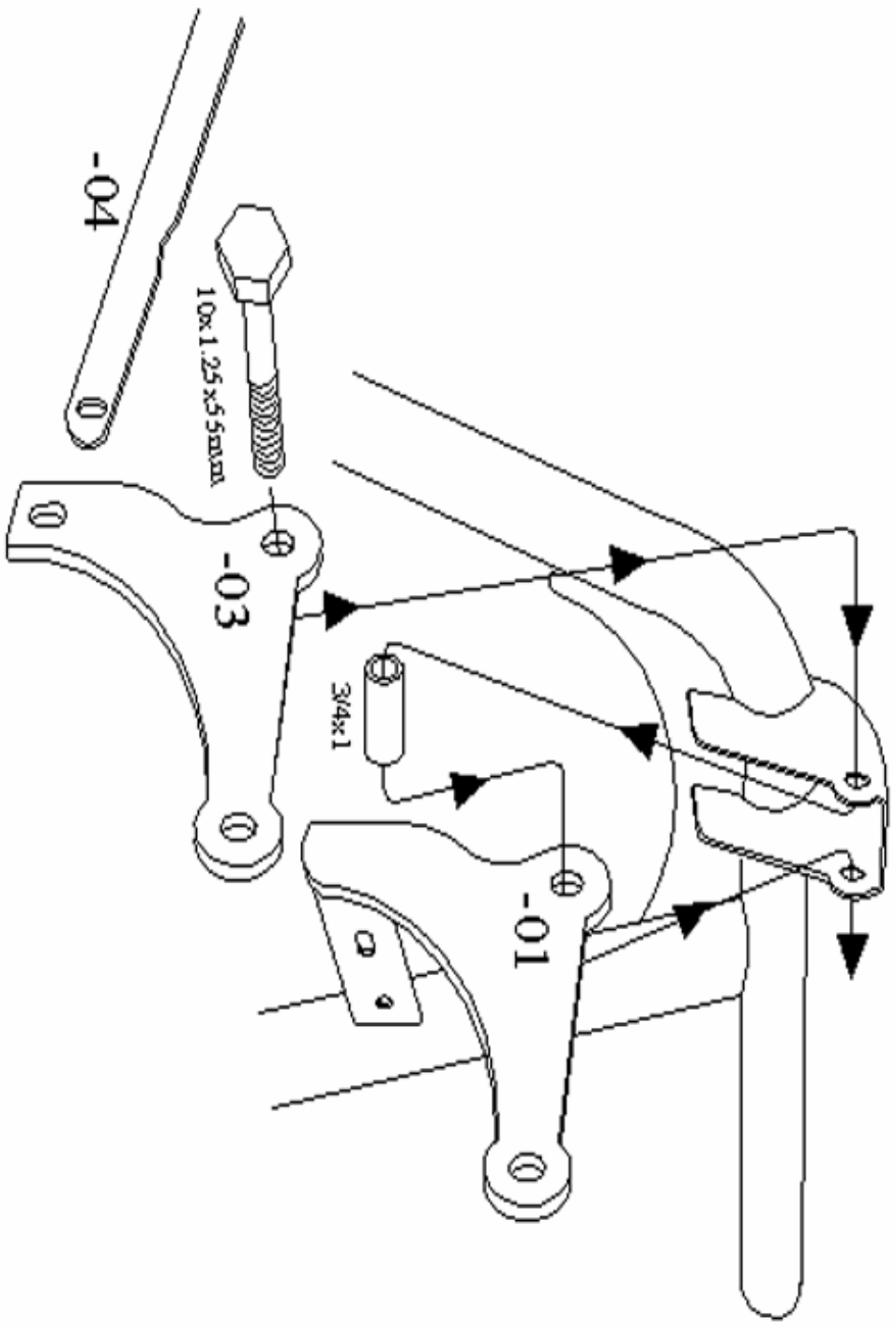

ASSEMBLY FOR BAG #2

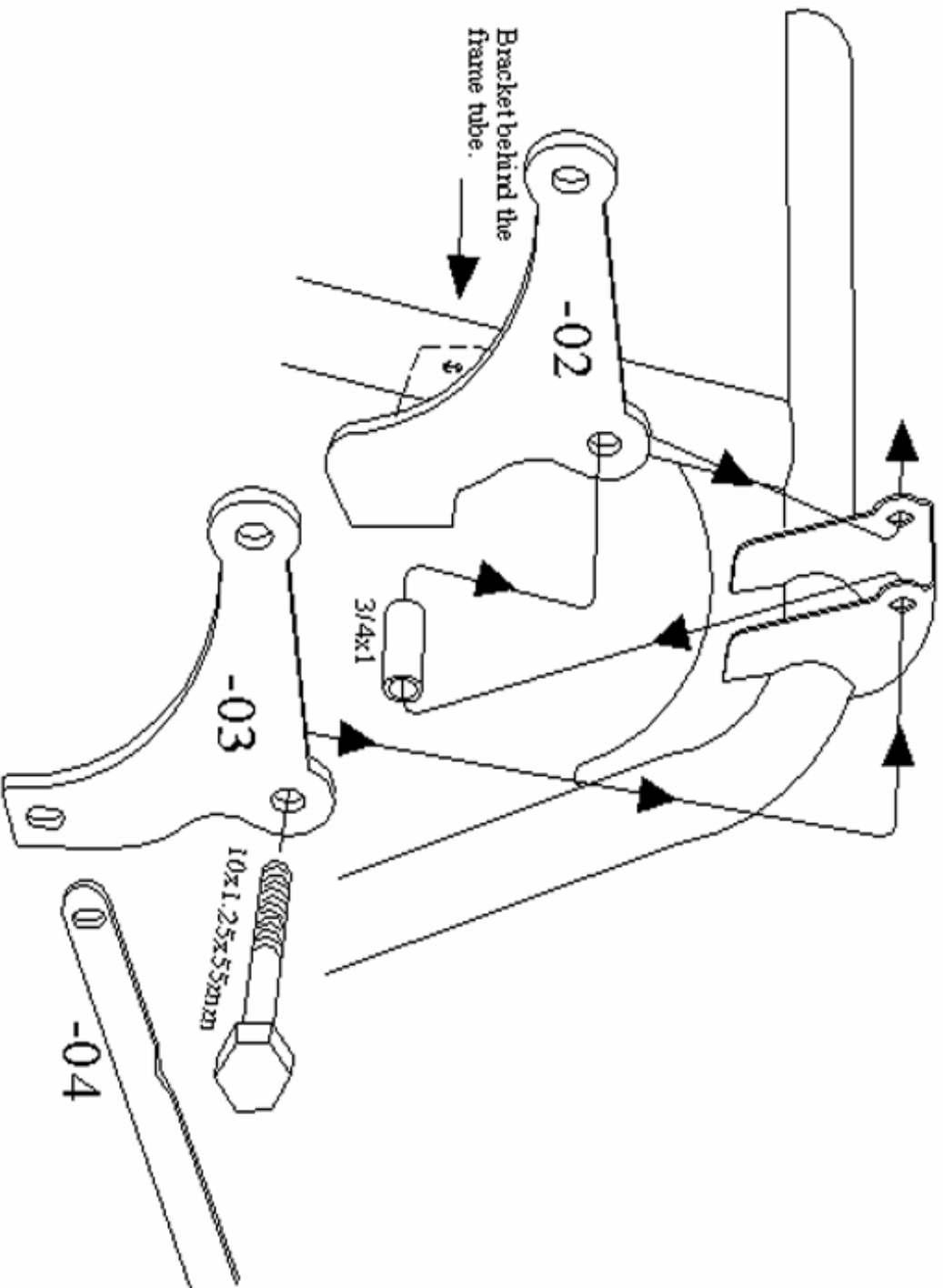

ASSEMBLY FOR BAG #3&4

Left Hand Side Shown

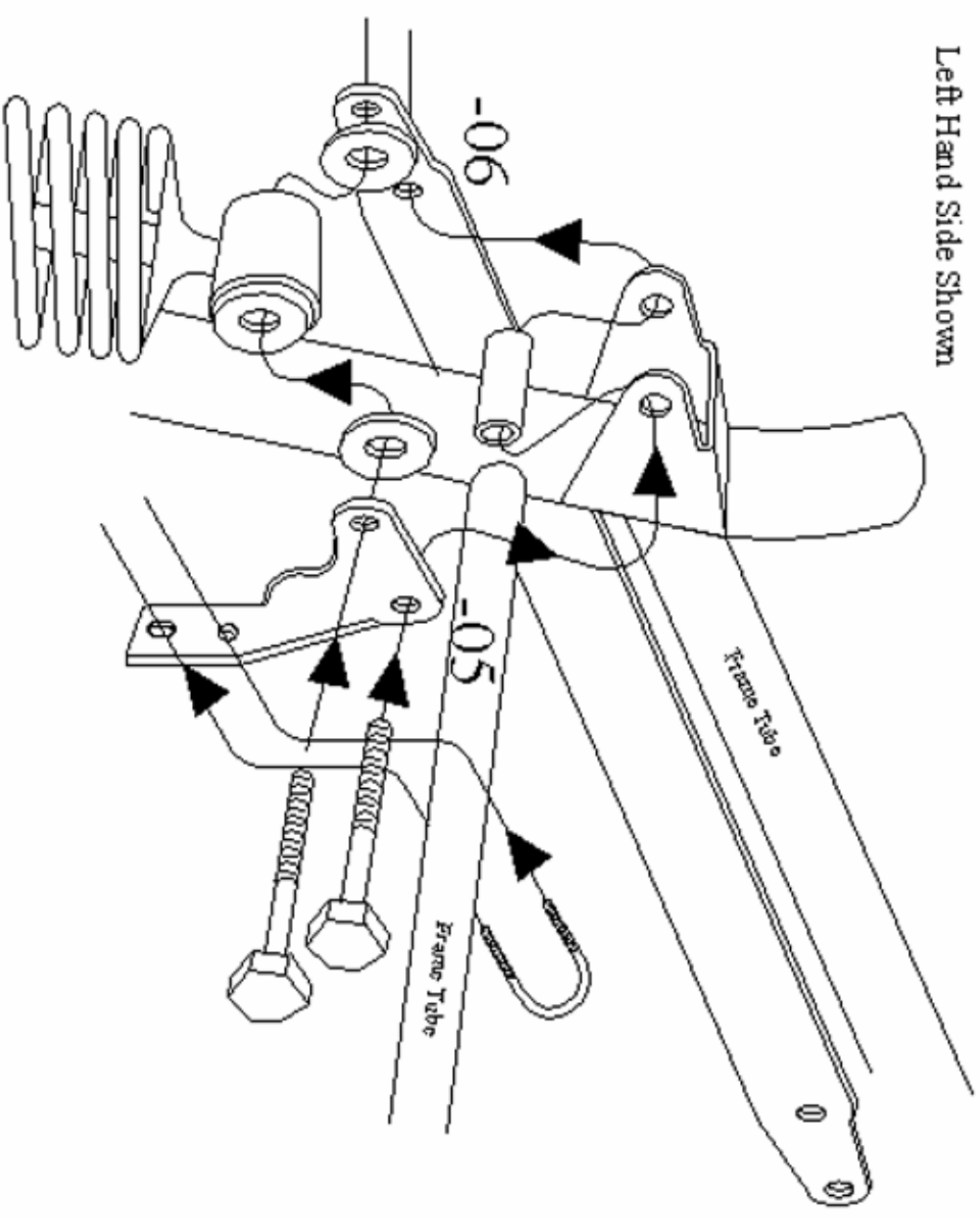

ASSEMBLY FOR Sway Bar

